

INTERNATIONAL TYPICAL OR BOOM CONFIGURATION - TS-774 (TC READY)

DO NOT SCALE DRAWING

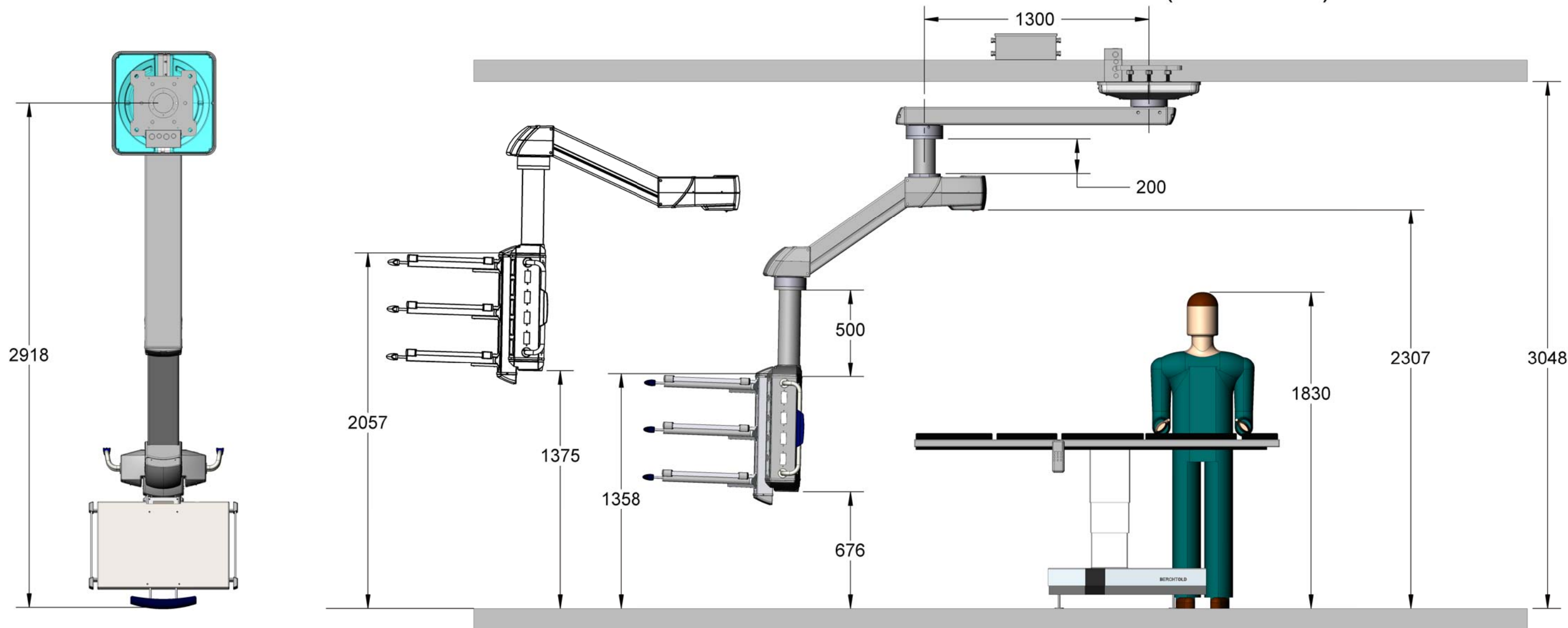

Typical Equipment Boom				
Country	Standard Gas	Standard Gas Offering	Standard Electric	Standard Power Offering
Spain - Option 1	Carbuos (max. 14)	2 med air, 2 vac, 2 O2, 1 AGFS	Schuko (max. 11)	11
Spain - Option 2	Pegisdan (max. 14)	2 med air, 2 vac, 2 O2, 1 AGFS	Schuko (max. 11)	11
Germany/China	DIN (max. 10)	2 med air, 2 vac, 2 O2, 1 AGFS	Schuko (max. 11)	11
Australia - Option 1	ESCO (max. 13)	2 med air, 2 vac, 2 O2, 2 Waste Gas Options	Clipsal (max. 24)	24
Australia - Option 2	Comweld (max. 9)	2 med air, 2 vac, 2 O2, 2 Waste Gas Options	Clipsal (max. 24)	24
United Kingdom	GEM 10 (max. 9)	2 med air, 2 vac, 2 O2, 1 AGSS	UK Blue Med Outlet (max. 11)	11
Italy	Delta P (max. 11)	2 med air, 2 vac, 2 O2, 1 AGSS, and 1 AGSS active unit	Schuko (max. 11)	11
France	Unknown at this time	Unknown at this time	Unknown at this time	

NOTE: Any changes to the standard will result in a predetermined upcharge. No low voltage outlets provided standard.

NOTES:

- SERVICE MODULE SHALL INCLUDE 3 POWERED PLATFORMS
- NO LOW VOLTAGE OPTIONS PROVIDED - THIS WILL BE UP CHARGED TO THE CUSTOMER IF REQUESTED.
- PNEUMATIC AND ELECTROMECHANICAL BRAKES

I confirm the ceiling height and agree with the dimensions as drawn and understand that any changes made after an order is in production will result in a change order fee and a shipment delay.

PROJECT:
**TYPICAL OR CONFIGURATION
INTERNATIONAL
TS-774 (TC READY)**

BERCHTOLD Corp.
1950 Hanahan Rd.
N. Charleston, SC 29406
(800)243-5135

REV:	DATE:	REV BY:	DESCRIPTION:
-	-	-	-
-	-	-	-
-	-	-	-

Authorized Signature: _____
Title: _____ Date: _____
Delivery Date Required: _____

SCALE: **1:24** QUANTITY: _____
FILENAME: **M1009002E_1**
SALES: **MARKETING**
DRAWN BY: **JHM** DATE: **10-1-09**

